

HRM-12

CON-E-CO®



Horizontal Reversing Mixer

**SOLID PRODUCTS.
SOLID PERFORMANCE.**

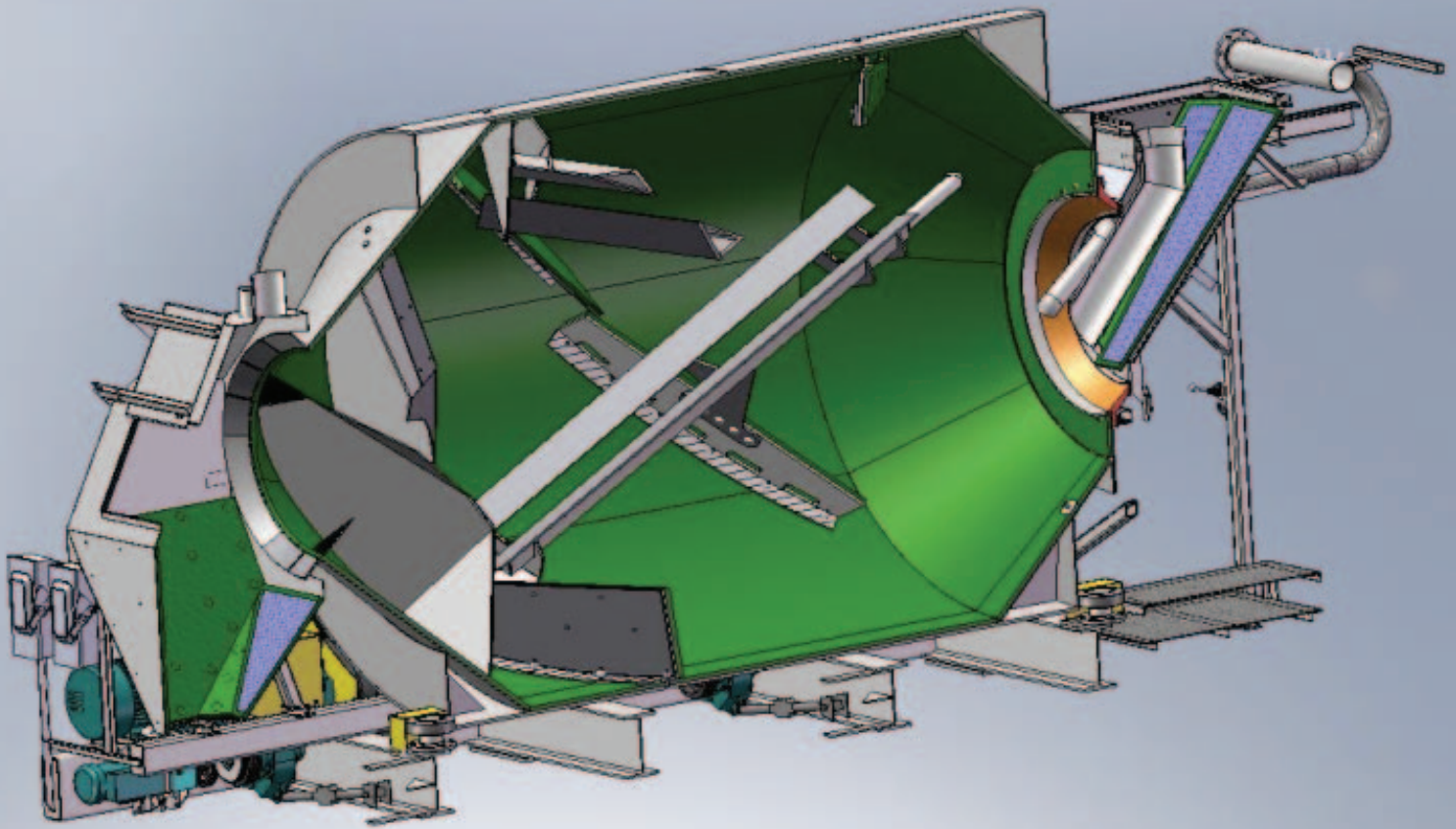

The Horizontal Reversing Mixer reduces maintenance costs, operates quieter, minimizes environmental impact and provides aggressive mixing action. All of these benefits add up to nothing less than what you would expect from CON-E-CO: quality engineering, industry-leading batch plants, breakthrough innovation, a strong dealer network and unbeatable factory support. It's the embodiment of "Solid Products. Solid Performance."

FEATURES

Non-tilting operation



Rubber tire drive system



BENEFITS

Eliminates hydraulic system maintenance – eliminates wear on tilt pins – requires less overhead clearance to reduce building cost

Eliminates gear lube maintenance that results in a more environmentally friendly operation – quiet operation for reduced sound levels inside building

FEATURES

Sealed mixing drum with infinite variable speed discharge rate

Climate controlled U.L.-rated service panel

Isolated resistor bank

High traction drive system with "Purpose Built" 23" diameter drive tires with heat dissipating grooves

Drive motors wired to individual disconnects

Five-hp single-phase emergency drives with hinged engagement

Bolt in paddles manufactured in jig to ensure proper fit

Dual element paddles supported from mixer / discharge paddles

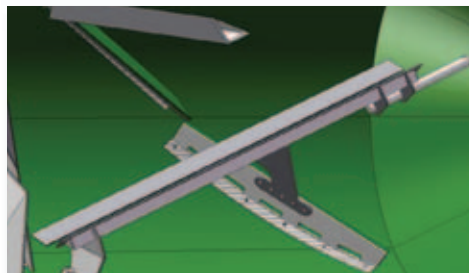
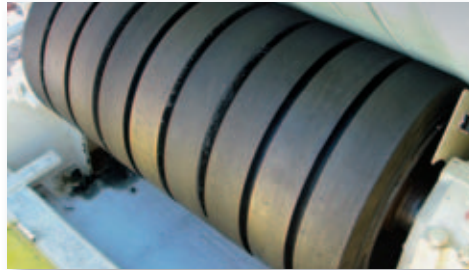

BENEFITS

Reduces splatter and dust for a cleaner operation

– Optimizes mixer truck charging and requires less CFM to capture dust

Cools variable speed frequency drive to promote longer and more trouble free life and provide a nearly dust free environment

Dissipates motor generated 58,000 watt feedback during reversing to protect the variable speed frequency drive

Increased contact virtually eliminates tire slippage. Grooves minimize tire blistering and heat build up

Enables isolation of each motor for maintenance and reduces expensive field wiring

Operates with single-phase generator
– Hinged style engagement allows a quick and more hassle free operation in an emergency situation

Eliminates field torching of paddle supports
– Eliminates field welding to reassemble
– Simple bolt in replacement for less down time

No center support structure reduces concrete build-up

FEATURES

Mixing / discharge blades furnished with open slots between paddles and drum



Advanced urethane inlet seal

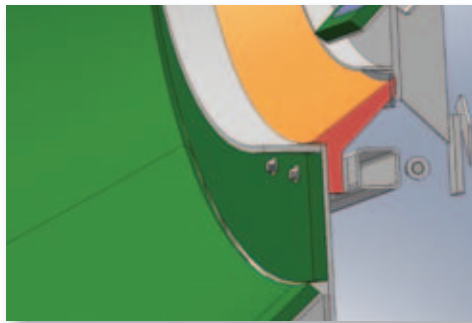

36" Retractable inlet chute with removable bolt on inlet ring

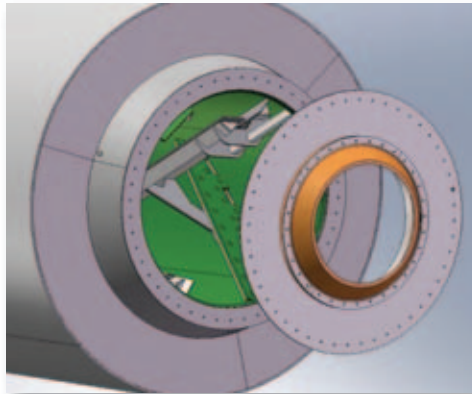

Precise factory drive alignment with built-in precision field realignment

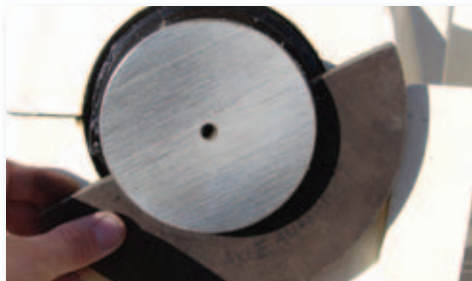

Six-foot tall perimeter fencing with four foot wide removable panels

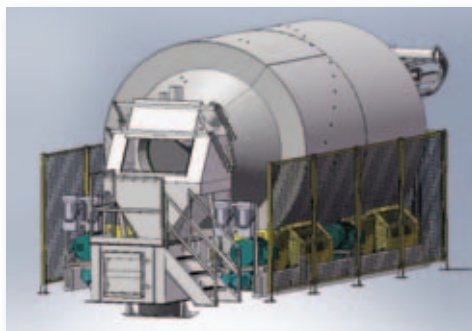

BENEFITS

Reduces concrete build up on discharge side of paddles for less daily clean up and maintenance

Spillage free mixer charging with no maintenance urethane seal

Easy access for daily clean up.
– Removable inlet ring provides access for removal and insertion of paddles and discharge blades

Alignment is critical to proper operation – built-in field alignment system allows simple field realignment

Provides guarding for moving parts and access for maintenance

HRM Model 12 Horizontal Reversing Mixer

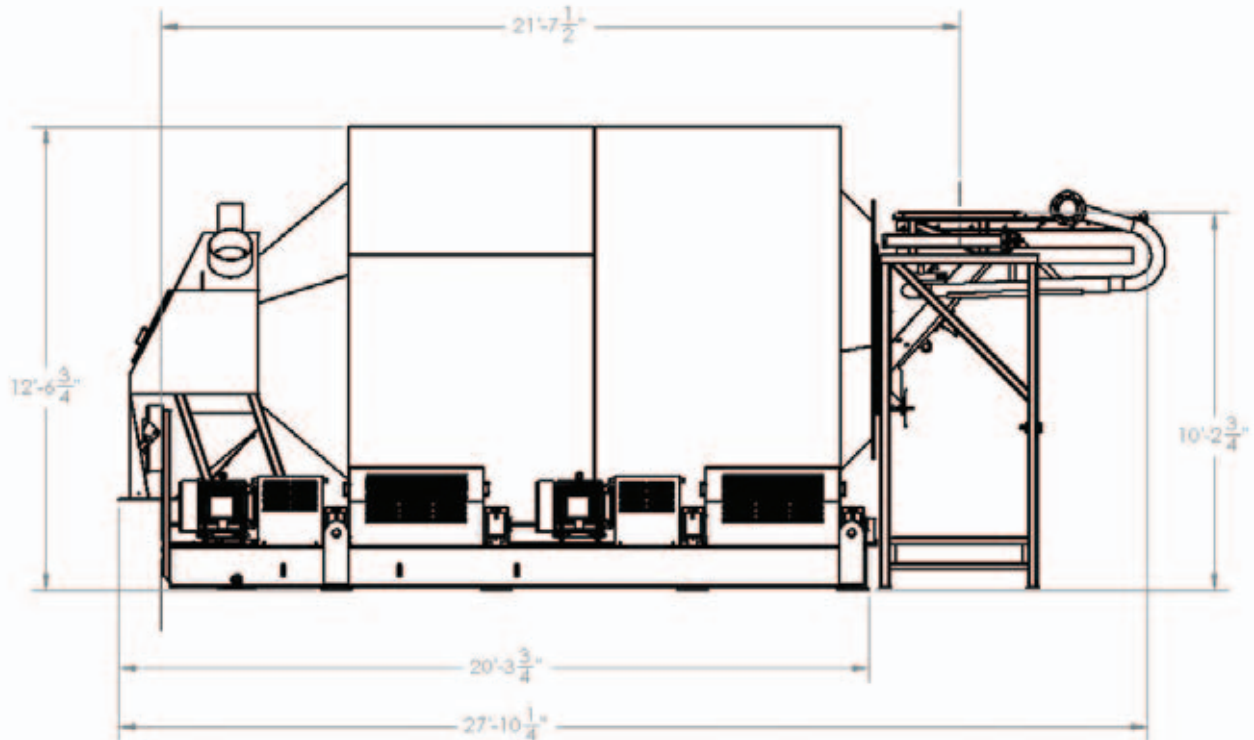

SPECIFICATIONS:

CAPACITY

- 12 cubic yards

MIXER DRUM

- 38" diameter inlet
- 46" diameter outlet
- 3/4" steel drum shell
- 3/8" steel inlet and outlet cones
- 1" polyurethane blade liners on drum and cones

MIXING PADDLES

- Six bolt-in A36 steel drum mixing paddles
- 1" polyurethane furnished on mixing side of drum shell paddles
- A.R. 400 1/4" steel wear plate on discharge side of drum shell paddles
- Three bolt-in dual element 1/2" steel paddles
- A.R. 400 1/4" steel wear plate on dual element paddles
- Three bolt-in A36 steel discharge paddles
- A.R. 400 1/4" steel wear plate on discharge paddles

DRIVES

- Four 50 H.P. T.E.F.C. motors
- Enclosed gear reducers
- High capacity friction drive
- Hinged 230-volt, single-phase emergency drives

ELECTRICAL SYSTEM

- 460 volt
- Variable-frequency reversing drive control
- Climate-controlled panel enclosure
- Circuit breaker main disconnect
- NEMA 12 enclosures
- U.L. Listed panels
- Knife switch furnished for each motor

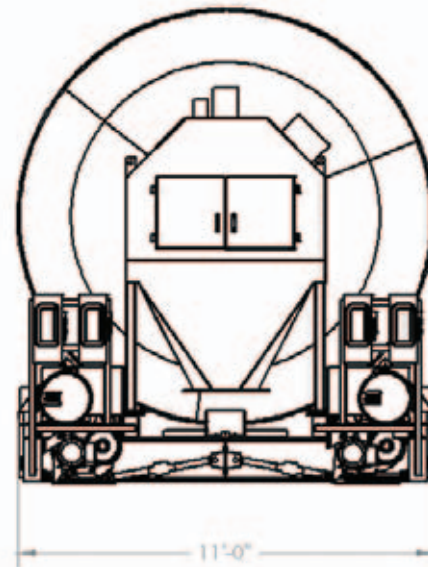

INLET CHARGING HOPPER

- Powered 36" travel retractable assembly
- 6" water manifold with dual 4" outlets
- One-piece urethane charging seal
- Ceramic-tiled 1" urethane hopper liners
- 10" diameter cement tube

DISCHARGE HOPPER/DUST CONTROL SHROUD

- Transit mixer charging shroud
- 1" urethane liner at impact area
- Provision for camera view port and light
- Dust control suction inlet ring

NOTE: In accordance with CON-E-CO's policy of constantly improving its products, these specifications are subject to change without notice.



P.O. Box 430 • Blair, NE 68008 • 402-426-4181 • www.con-e-co.com