

CON-E-CO®

An Oshkosh Truck Corporation Company

Lo-Pro® 427



Expandability

Versatility



Mobility



Performance!

- 12 cubic yard batcher capacity, up to 300 yards per hour
- 14-ft. discharge height, 180° truck access
- 427-barrel on-board cement bin
- optional 409-barrel on-board split compartment cement bin
- low profile, reduced-height aggregate bin
- hydraulic self-erect, self-leveling; no crane needed
- expandable cement and aggregate storage
- overhead dust control system
- expandable to central mix option
- optional portable foundation compatibility

CON-E-CO®

An Oshkosh Truck Corporation Company

*The industry leader in **concrete batch plants and mixers!***

Lo-Pro 427

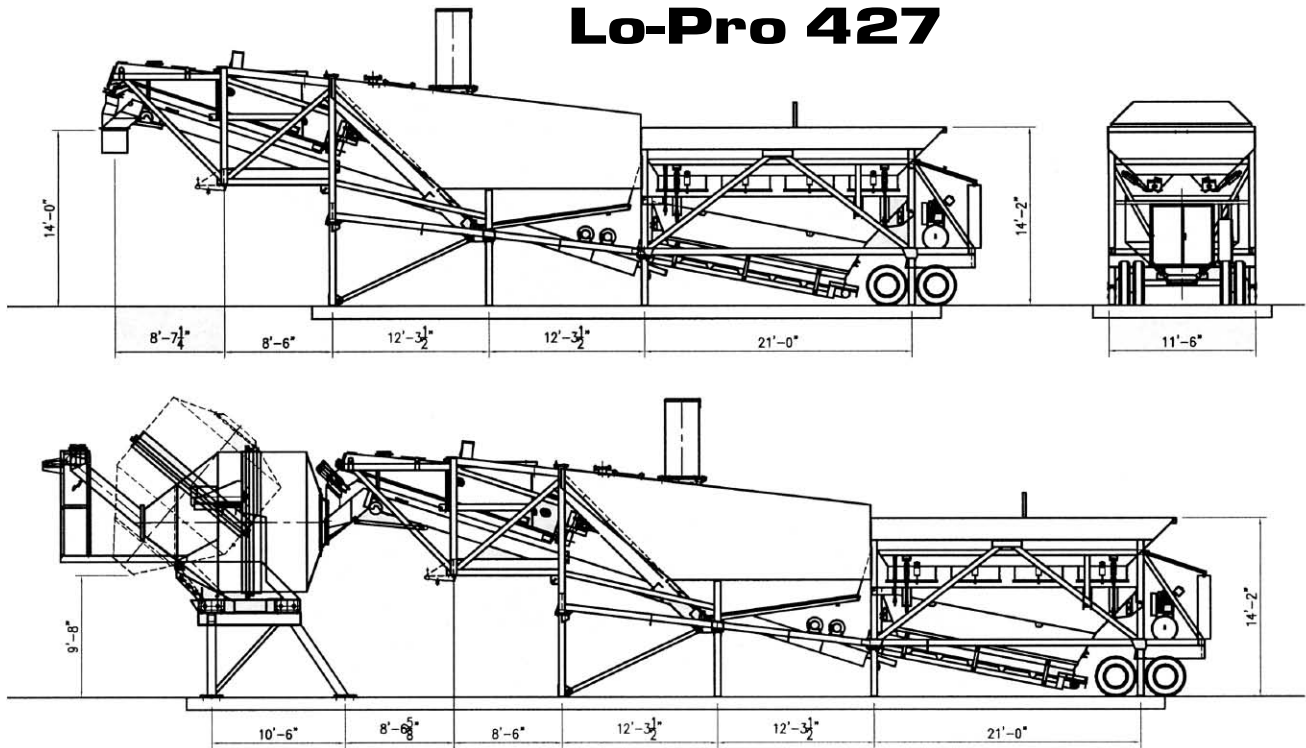

SPECIFICATIONS

PRODUCTION CAPACITY:

Theoretical capacity — 2-1/2 to 3 minute cycles

BATCHER CAPACITY:

Aggregate — 12 cubic yards (9.2 cubic meters)
Cement — 12 cubic yards (9.2 cubic meters)
Scales — load cells

AGGREGATE BATCHER CONVEYOR:

30" wide (762 mm), 10 or 15 horsepower drive. Optional 36" (914 mm), 20 horsepower

AGGREGATE DISCHARGE CONVEYOR:

30" wide (762 mm), 35" trough with 15 horsepower drive. Optional 36" (914 mm), 20 or 40 horsepower

CEMENT BATCHER BLENDING SCREW:

14" diameter (360 mm), 15 horsepower. Optional 18" diameter (460 mm), 20 or 25 horsepower

CEMENT FEEDER SCREWS:

Two 9" diameter (230 mm) with 15 horsepower drive. Optional 12" diameter (300 mm), 20 horsepower

CEMENT AERATION:

5 horsepower, high volume, low pressure blowers

HIGH PRESSURE AIR COMPRESSOR:

7.5 horsepower with 80 gallon (0.30 cubic meters) receiver. Optional 10, 15, 20 or 30 horsepower, 120 gallon (0.45 cubic meters)



Mobile tow-away self-erecting batch plant.

ELECTRICAL:

460 volt, 3-phase with 120 VAC transformer for control voltage. All motors are TEFC. All motor circuit wiring protected by individual circuit breakers. Electrical components housed in NEMA steel enclosures. Wiring in conduit.

BATCH CONTROL SYSTEM:

Semi-automatic cut-off cement by presets on digital readouts. Push-button for electric over air on gates. Optional fully-automatic computerized batch control system

WATER METER:

CON-E-CO 2" diameter (50 mm) all-electronic, stainless steel turbine. 25 to 300 gallons (87 to 1,740 liters) per minute. Optional 3" diameter (77 mm) with up to 500 gallons (1,740 liters) per minute or weighed water with holding tank

TRANSPORTATION SYSTEM:

Rear-mounted, tandem axle with eight tires, wheels, air brakes, heavy duty spring suspension, tail end brake lights, and fifth wheel rub plate with king pin

STORAGE BIN CAPACITIES:

AGGREGATE	HEAPED VOLUME
	50 to 100 cubic yards (38 to 76 cubic meters)
CEMENT I	GROSS VOLUME
	1,708 cubic feet (47.5 cubic meters)
CEMENT II	GROSS VOLUME
	1,340 to 3,060 cubic feet (37 to 85 cubic meters)

DIMENSIONS:

Towing length	60' 0" (18,000 mm)
Towing height	14' 0" (4,200 mm)
Towing width	11' 6" (3,450 mm)
Empty weight, total	55,000 lbs (24,750 kg)
Shipping volume	11,300 cubic feet (340 cubic meters)

NOTE:

In accordance with CON-E-CO's policy of constantly improving its products, the above specifications are subject to change without notice. CON-E-CO assumes no responsibility for foundation design. Consult factory for column loadings.

Proud Member of



PRINTED IN USA

CON-E-CO®

An Oshkosh Truck Corporation Company

Address: P.O. Box 430
Blair, NE 68008

Phone: (402) 426-4181

Fax: (402) 426-4180

Website: www.con-e-co.com

E-Mail: sales@con-e-co.com